



DATASHEET

JD092B-C

Product specifications



JD092B-C

10Gb/s 10km SFP+ Optical Transceiver

Product Features

- ✓ Duplex LC Connector
- ✓ Support hot-pluggable
- ✓ Metal with lower EMI
- ✓ Excellent ESD protection
- ✓ DFB Transmitter and PIN Receiver
- ✓ Distance up to 10Km on 9/125um SMF
- ✓ Single 3.3V power supply and Low power dissipation <1.0W
- ✓ GR-253-CORE compliant
- ✓ RoHS Compliant and Lead-Free
- ✓ Compliant with IEEE 802.3ae
- ✓ Compliant with SFP+ MSA: SFF-8431 Rev4.1
- ✓ Compliant with SFF-8472 Rev11.0

Applications

- ✓ 10GBASE-LR/LW
- ✓ 10G Fibre Channel

Regulatory Compliance

- ✓ ESD to the Electrical PINs: compatible with MIL-STD-883E Method 3015.4
- ✓ ESD to the LC Receptacle: compatible with IEC 61000-4-2
- ✓ EMI/EMC compatible with FCC Part 15 Subpart B Rules, EN55022:2010
- ✓ Laser Eye Safety compatible with FDA 21CFR, EN60950-1& EN (IEC) 60825-1,2

✓ RoHS compliant with EU RoHS Directive 2011/65/EU

Pin Descriptions

Pin	Symbol	Name/Description	Ref.
1	VeeT	Transmitter Ground (Common with Receiver Ground)	1
2	TX Fault	Transmitter Fault. LVTTTL-O	2
3	TX Disable	Transmitter Disable. Laser output disabled on high or open. LVTTTL-I	3
4	SDA	2-Wire Serial Interface Data Line(Same as MOD-DEF2 in INF-8074i). LVTTTL-I/O	
5	SCL	2-Wire Serial Interface Data Line(Same as MOD-DEF2 in INF-8074i). LVTTTL-I	
6	Mod_ABS	Module Absent, Connect to VeeT or VeeR in Module.	4
7	RS0	Rate Select 0, optionally controls SFP+ module receiver LVTTTL-I	5
8	LOS	Loss of Signal indication. Logic 0 indicates normal operation. LVTTTL-O	2
9	RS1	Rate Select 1, optionally controls SFP+ module transmitter. LVTTTL-I	5
10	VeeR	Receiver Ground (Common with Transmitter Ground)	1
11	VeeR	Receiver Ground (Common with Transmitter Ground)	1
12	RD-	Receiver Inverted DATA out. AC Coupled. CML-O	
13	RD+	Receiver Non-inverted DATA out. AC Coupled. CML-O	
14	VeeR	Receiver Ground (Common with Transmitter Ground)	1
15	VccR	Receiver Power Supply	
16	VccT	Transmitter Power Supply	
17	VeeT	Transmitter Ground (Common with Receiver Ground)	1
18	TD+	Transmitter Non-Inverted DATA in. AC Coupled. CML- I	
19	TD-	Transmitter Inverted DATA in. AC Coupled. CML- I	
20	VeeT	Transmitter Ground (Common with Receiver Ground)	1

Notes:

1. The module signal ground contacts, VeeR and VeeT, should be isolated from the module case.
2. This contact is an open collector/drain output and should be pulled up to the Vcc_Host with resistor in the range 4.7K Ω to 10K Ω . Pull ups can be connected to one or several power supplies, however the host board design shall ensure that no module contact has voltage exceeding module VccT/R +0.5V.
3. Tx_Disable is an input contact with a 4.7K Ω to 10K Ω pull-up resistor to VccT inside module.
4. Mod_ABS is connected to VeeT or VeeR in the SFP+ module. The host may pull the contact up to Vcc_Host with a resistor in the range from 4.7K Ω to 10K Ω . Mod_ABS is asserted "High" when the SFP+ module is physically absent from a host slot.
5. RS0 and RS1 are module inputs and are pulled low to VeeT with > 30 k Ω resistors in the module. RS0 optionally selects the optical receive signaling rate coverage. RS1 optionally selects the optical transmit signaling rate coverage.

These contacts can also be used for RS0 and RS1 if implementing SFF8079. See SFF8079 for details. RS1 is commonly connected to VeeT or VeeR in the classic SFP modules. The host needs to ensure that it will not be damaged if this contact is connected to VeeT or VeeR in the module.

The SFP+ module provides two inputs RS0 and RS1 that can optionally be used for rate selection. RS0 controls the receive path signalling rate capability, and RS1 controls the transmit path signaling rate capability. The host and module may choose to use either, both, or none of these functions. Because contact 9 in the classic SFP INF-8074i is connected to VeeR, an SFP+ host utilizing RS1 must provide short circuit protection.

This rate select functionality can also be controlled by software as defined by SFF-8472. Optionally the rate select methods of Part 2 of SFF-8079 may be used instead of the method

described here by setting the management declaration bit (A0h byte 93 bit 2) to 1, see SFF-8472.

Parameter	State	Conditions
RS0	Low	Rx signally rate less than or equal to 4.25GBd.
	High	Rx signally rate great than 4.25GBd.
RS1	Low	Tx signally rate less than or equal to 4.25GBd.
	High	Tx signally rate great than 4.25GBd.

Pin-out of Connector Block on Host Board

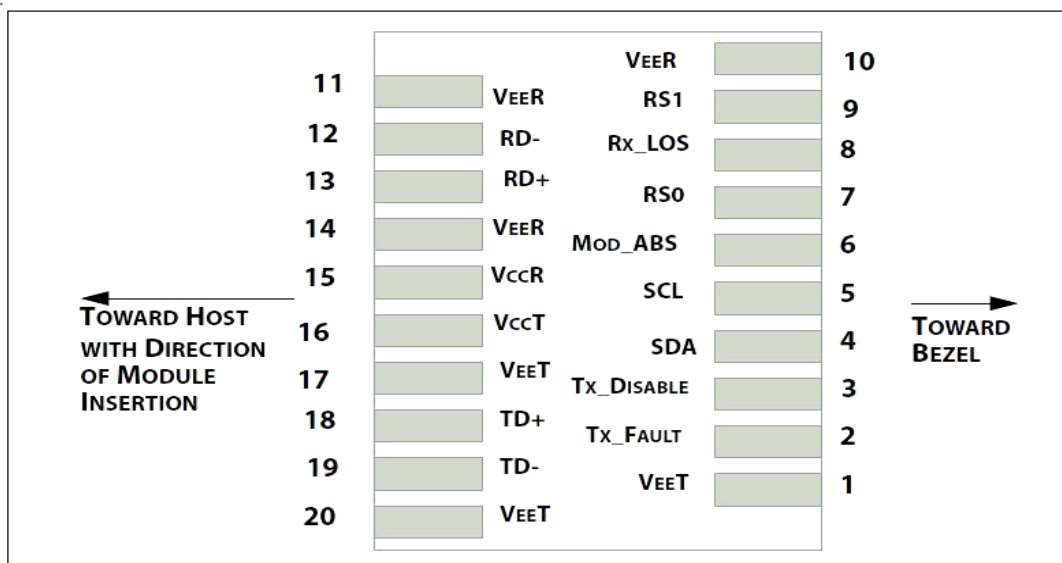

Recommend Circuit Schematic

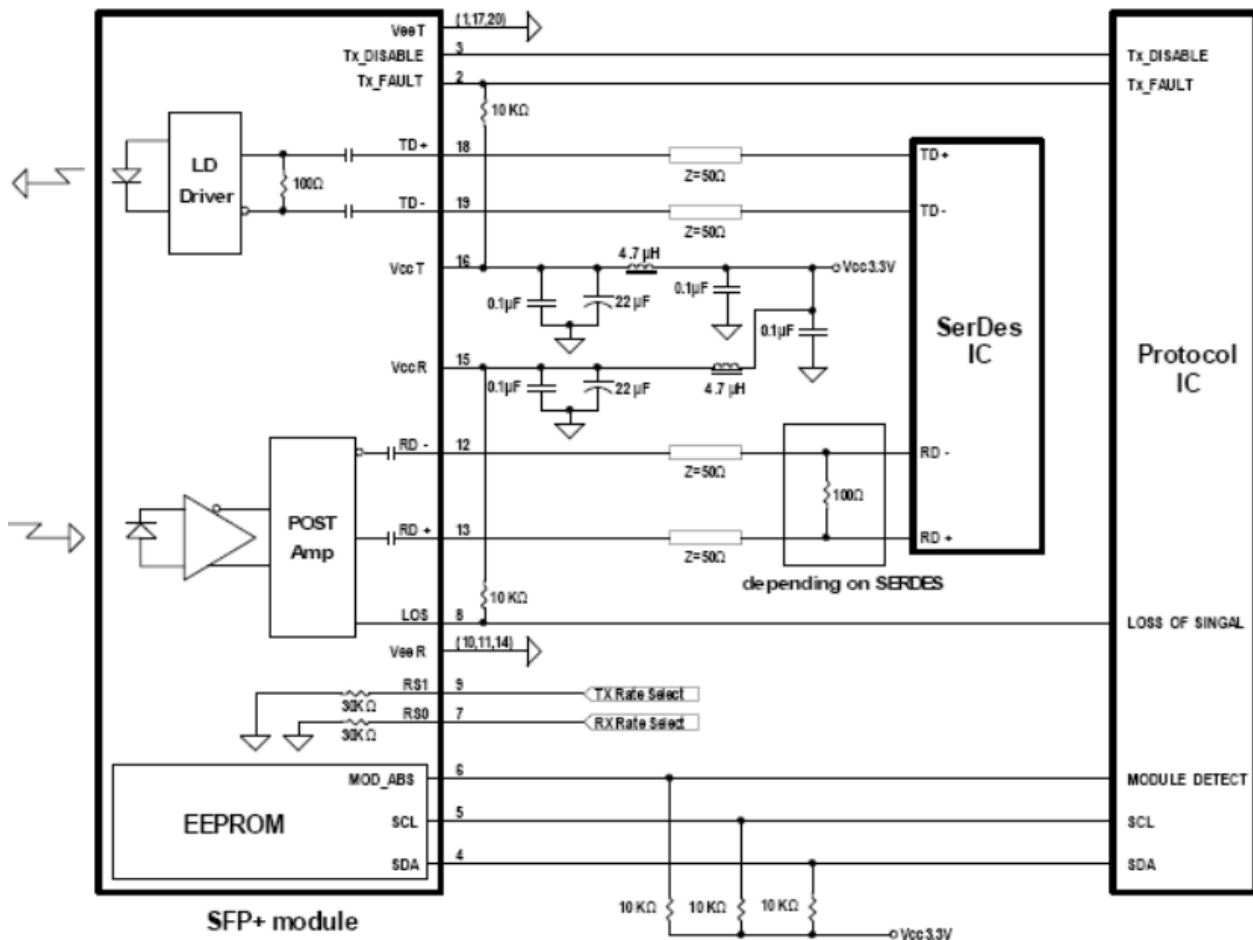

Absolute Maximum Ratings

Parameter	Symbol	Min	Typ	Max	Unit	Ref.
Maximum Supply Voltage	Vcc	-0.5		+4.0	V	
Storage Temperature	TS	-40		+85	°C	
Operating Humidity	RH	5		95	%	

Recommended Operating Conditions

Parameter	Symbol	Min	Typ	Max	Unit	Ref.
Power Supply Voltage	Vcc	3.13	3.30	3.47	V	
Power Supply Current	Icc	-	-	300	mA	
Case Operating Temperature	Tc	-5	-	+70	°C	2
	Tc	-40	-	+85	°C	3
Data Rate	-	9.95	10.3	11.3	Gbps	

9/125um G.652 SMF	Lmax	-	-	10	km	
-------------------	------	---	---	----	----	--

Electrical Characteristics

Parameter	Symbol	Min	Typ	Max	Unit	Ref.
Transmitter						
Differential data input swing	V _{in,pp}	120	600	850	mV	
Input differential impedance	Z _{in}	90	100	110	Ω	
TX Disable-High	-	2.0	-	V _{cc} +0.3	V	
TX Disable-Low	-	V _{ee} -0.3	-	0.8	V	
TX Fault-High	-	2.0	-	V _{cc} +0.3	V	
TX Fault-Low	-	V _{ee} -0.3	-	0.8	V	
Receiver						
Differential data output swing	V _{out, pp}	300	600	850	mV	
Output Differential Impedance	Z _{in}	90	100	110	Ω	
LOS-High	-	2.0	-	V _{cc} +0.3	V	
LOS-Low	-	V _{ee} -0.3	-	0.8	V	

Optical Characteristics

Parameter	Symbol	Min	Typ	Max	Unit	Ref.
Transmitter						
Output Opt. Power	AOP	-5	-	+0.5	dBm	1
Optical modulation amplitude	P(OMA)	-5.2	-2		dBm	
Extinction Ratio	ER	3.5	-	-	dB	
Transmitter and Dispersion Penalty	TDP	-	-	3.2	dB	
Average Launch power of OFF TX	P _{off}	-	-	-45	dBm	
Optical Wavelength	λ	1260	1310	1355	nm	
Spectral Width(-20dB)	Δλ	-	-	1	nm	

Optical Return Loss Tolerance	ORLT			12	dB	
Side Mode Suppression Ratio	SMSR	30			dB	
Relative Intensity Noise	RIN	-	-	-128	dB/Hz	
Eye Diagram	Compatible with IEEE 802.3-2005					
Receiver						
Receiver Sensitivity	PIN	-	-	-13	dBm	1
Overload		0.5	-	-	dBm	1
Receiver Reflectance	-	-	-	-12	dB	
Optical Center Wavelength	λ C	1260	-	1610	nm	
Los Assert		-30	-	-	dBm	
Los De-assert		-	-	-15	dBm	
Los hysteresis		0.5	-	5	dB	

Notes:

1. BER $\leq 10^{-12}$ @PRBS²³¹-1 at 10.3125Gb/s.
2. For commercial temp version
3. For industrial temp version

Mechanical Specifications

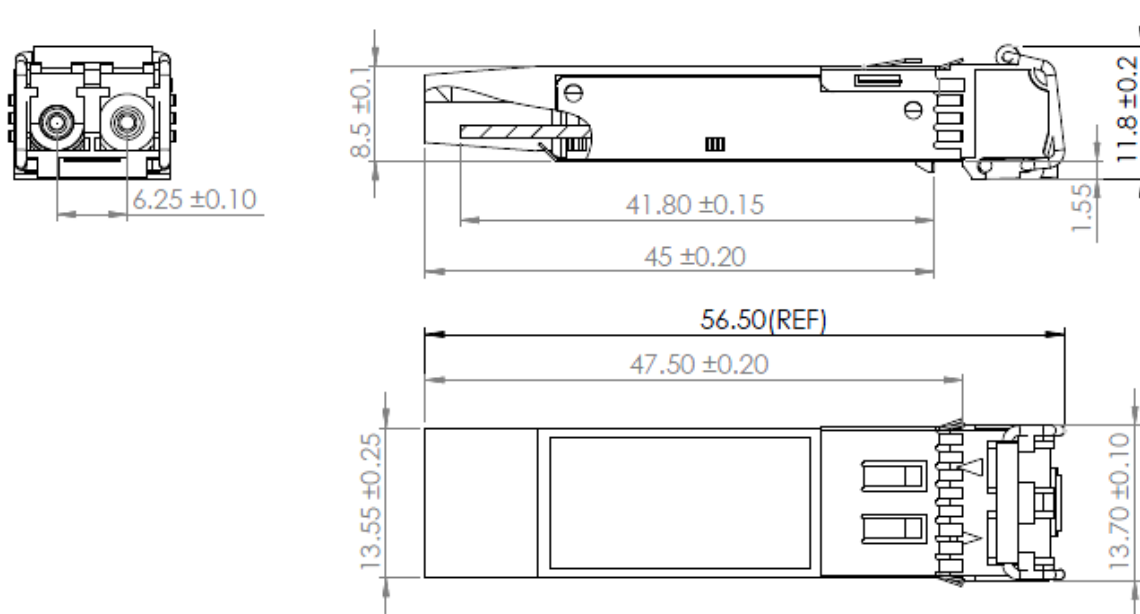

JD092B-C

EEPROM Information

EEPROM memory map specific data field description is as below:

2 wire address 1010000X (A0h)		2 wire address 1010001X (A2h)	
0	Serial ID Defined by SFP MSA (96 bytes)	0	Alarm and Warning Thresholds (56 bytes)
95	Vendor Specific (32 bytes)	55	Cal Constants (40 bytes)
127	Reserved, SFF8079 (128 bytes)	95	Real Time Diagnostic Interface (24 bytes)
255		119	Vendor Specific (8 bytes)
		127	User Writable EEPROM (120 bytes)
		247	
		255	Vendor Specific (8 bytes)

Digital Diagnostic Monitoring Interface

The digital diagnostic monitoring interface also defines another 256-byte memory map in EEPROM, which makes use of the 8 bit address 1010001X (A2h). The monitoring specification of this product is described in this table.

Parameter	Range	Accuracy	Calibration
Temperature	-5 to +85°C	±3°C	Internal (note 1)
	-40 to +95°C	±3°C	Internal (note 2)
Voltage	2.97 to 3.63V	±3%	Internal
Bias Current	0 to 100mA	±10%	Internal
TX Power	-5 to +0.5dBm	±2dB	Internal
RX Power	-13 to 0.5dBm	±3dB	Internal

Notes:

1. For commercial temp version
2. For industrial temp version